

Investigation of Pavement Maintenance Applications of IntellidriveSM (Final Report):
Implementation and Deployment Factors for Vehicle Probe-Based Pavement Maintenance
(PBPM)

May 5, 2011

Jeremy Dawkins
Richard Bishop (Bishop Consulting)
Buzz Powell
David Bevely

Auburn University

Executive Summary

This project investigated whether vehicular data available from connected vehicles can be used to measure pavement conditions, particularly as compared to current techniques used by DOTs to measure the International Roughness Index (IRI). The results were then analyzed in terms of a potential national deployment to develop a preliminary Concept of Operations, list system requirements, analyze deployment issues, and conduct a comparative cost analysis.

Pavement maintenance is a vital function for transportation agencies. Current methods are quite costly, entailing visual inspections from agency staff and traversing the roads using specially-equipped measurement vehicles. Quantitative pavement assessment relies on longitudinal profile measurements as defined by the international roughness index (IRI). In current practice, pavement assessment is conducted only periodically due to the limited availability of specialized equipment and the high cost.

Connected vehicles offer an alternative. Given the sensing and computing power on today's vehicles, each vehicle on the road is a storehouse of valuable information about current travel and road conditions. A key idea for probe data systems is in collecting data that already exists on-board vehicles. Fortunately, the sensor set on today's automobiles have been evolving steadily in recent years in ways that are relevant to pavement assessment.

Probe data activities in Europe have led the way in examining business-viable approaches. Approximately 70,000 vehicles are now reporting probe data in Germany, generating 30M records daily. Building on the European approach, first generation probe data systems are expected to be operating within the U.S. in the next few years, coming before DSRC roadside units are available in significant numbers. First generation probe systems will be well served by commercial wireless services; they may transition to DSRC in the future if there are cost / performance reasons to do so.

Assessing pavement quality through probe data is called Probe Data Performance Management (PDPM). Using the probe vehicle's onboard sensors, the roughness of sections of road can be assessed. Simple algorithms using the measurements from the onboard sensors can be related to the IRI of the road. In order to accurately relate the sensor measurements to the IRI the probe vehicle must be calibrated. Additionally the sensor measurements can be used to identify potholes or bumps on the road. The key for PDPM is to have enough vehicles reporting pavement-relevant data to be able to contribute to DOT pavement management programs. Some forms of probe data require a particular critical mass of reporting vehicles to keep up with changing conditions on the road; this is the case with traffic monitoring. By contrast, pavement quality changes much more slowly. While traffic can change substantially in a matter of minutes, potholes change on the order of hours (in severe situations) and pavement roughness changes on the order of months or years, depending on usage.

Therefore, even very low levels of PDPM vehicles can have some benefit. The benefit scales up with the number of reporting vehicles until saturation occurs. Therefore, the earliest

timeframe for a “full” deployment of PDPM would be early in the next decade. Nevertheless, beneficial data would begin flowing much sooner.

A PDPM fleet of 2.5M vehicles is estimated to be sufficient for nationwide coverage. The cost is estimated at \$10 per vehicle per year for data transmission and processing. Therefore, with these estimates the total costs would be \$25M annually for national coverage.

Current costs by states for IRI surveys range from \$10-\$30 per lane mile. The team performed some basic analysis to show that this \$25M figure calculated above for PDPM is between 12-20% of the national cost depending on the approach used (in-house versus contracted).

In an early deployment scenario in which only ten states were bearing the \$25M cost burden, the cost advantage for PDPM would depend on the lane mileage within the state. In an analysis of Alabama, California, Michigan, Texas, and Virginia, PDPM costs of \$2.5M per state would be lower for all the states except for Virginia, as compared to current methods.

PDPM offers the potential for cost-effective pavement assessment using sensors already on today’s automobiles. The roll-out of probe data services in the U.S. by car-makers is expected to begin near-term, based on existing approaches overseas. However, PDPM does not offer the type of business case to car-makers that traffic and weather information do. Therefore, the infrastructure community needs to stimulate a PDPM pavement data market at the national level, to motivate data providers to seek this information, which will motivate car companies to provide it.

The research team recommends that a pilot program be conducted with one or more states plus a car company who is a leader in probe data and has mature on-board systems that can easily provide probe data via cellular communications. The objective of the pilot study would be to take the results of Auburn’s study to a real-world setting, to gain experience with both the quality of the data as well as reporting management techniques. The pilot could also engage data service providers to begin to conceptualize a delivery mechanism to state DOTs.

I. Introduction

This document addresses Task 3 (Evaluation of Methodologies), Task 4 (Documentation) and Task 5 (Deployment Analysis) in the Cooperative Systems Pavement Maintenance Application Pooled Fund study conducted by Auburn University.

The goal of this project was to investigate if vehicular data available from connected vehicles can be used to measure pavement conditions, particularly as compared to current techniques used by DOTs to measure the International Roughness Index (IRI). Also detection and mapping of potholes is addressed. The research results were then analyzed in terms of a potential national deployment to develop a preliminary Concept of Operations, list system requirements, analyze deployment issues, and conduct a comparative cost analysis.

Key elements of this report are:

- a) Background on pavement management and probe data systems
- b) System Development and Analysis
- c) Documentation of prototype system
- d) Concept of operations
- e) System Requirements
- f) Deployment risks, constraints, opportunities
- g) Cost analysis
- h) Conclusion and Recommendations

Intended Audience

The audience for this document includes:

- Federal, state, county and city DOTs
- Public safety community
- Passenger vehicle manufacturers / light vehicle OEMs
- Traffic operations managers and planners who will make decisions regarding where to deploy system
- Designers of PBPM systems
- PBPM component suppliers
- Voluntary standards organizations that will be involved in standardizing the various elements of the PBPM system
- Research and development centers that conduct research on future enhancements of PBPM systems

II. Background

Current Practices in Pavement Management

Pavement maintenance is a vital function for transportation agencies. Current methods are quite costly, entailing visual inspections from agency staff and traversing the roads using specially-equipped measurement vehicles. Due to budget limitations, it can be challenging to conduct pavement assessments frequently enough to effectively monitor pavement conditions.

Quantitative pavement assessment relies on longitudinal profile measurements as defined by the international roughness index (IRI). Operations at Auburn's NCAT asphalt test track use the IRI as the key measurement factor in assessing pavement wear factors. In the field, transportation agencies must regularly measure/rate the quality of its pavements. Currently, this involves "manual" visual inspection and, in some cases, use of a specialized vehicle with ultrasonic and video sensors to measure rutting and other pavement distress. In current practice, pavement assessment is conducted only periodically due to the limited availability of specialized equipment and the high cost.

Identifying, mapping, and assessing the extent of potholes is also essential to pavement maintenance. Potholes can develop quickly in winter conditions, such that road crew inspections are not likely to keep up with the situation. Probe vehicle techniques based on connected vehicle technology hold particular promise in early detection of potholes.

Current State of the Art in Connected Vehicles

Given the sensing and computing power on today's vehicles, each vehicle on the road is a storehouse of valuable information about current travel and road conditions. Connected vehicles are a reality now – based on the emergence of telematics systems in passenger cars offering real-time traffic, weather, and automatic crash notification services, in addition to entertainment features. Current systems use the commercial wireless network to exchange data.

A key idea for probe data systems is in collecting data that already exists on-board vehicles, and not requiring any special equipment be fitted on vehicles just to serve the probe data function. Fortunately, the sensor set on today's automobiles have been evolving steadily in recent years in ways that are relevant to pavement assessment. Due to the broad introduction of Rollover Stability Control in high center of gravity vehicles, plus electronic stability control available in many passenger cars, vertical accelerometers and gyroscopes can now be found on millions of today's cars. Specifically, vertical accelerometers and roll rate gyroscopes are elements of rollover stability control (RSC) systems. In addition, suspension deflection sensors can also be found in some vehicles equipped with active or semi active suspensions. For instance, the Tenneco Continuously Controlled Electronic Suspension, which uses deflection sensors as part of their system, is installed on the Volvo S60R, V70R, S60, V70 and S80, the Ford S-Max and Galaxy and the Audi A6 and A6 Avant.

These accelerometer, gyroscopes, and suspension deflections from the vehicle are the primary sensors being used for the IRI estimation in this project. The research results show that the modes of motion which correspond most closely with the IRI are the vertical acceleration and pitch rate, and suspension deflections. Each of these sensors can be used to estimate the pavement quality.

From an implementation standpoint, the sensor data is readily available on the vehicle Controller Area Network (CAN) databus. While it cannot be tapped by aftermarket systems without special arrangements with the car-maker (which is rare), the car-makers themselves can add this sensor data to their probe data message fairly easily.

Current State of the Art in Aftermarket Devices

One potential method for collecting accelerometer data necessary to assess the pavement quality is to use the sensors available in many types of mobile devices. An advantage to this method is that it can potentially accelerate the implementation of the technology. Unfortunately when using cell phones for probe data there is no way to ensure that the phone is securely mounted to the vehicle. However with large amounts of data these anomalies could be averaged out. Using sensors onboard the vehicle has the advantage of guaranteeing quality in the data. Yet, the number of vehicles which have the required sensors will be smaller.

Standards

Standards for probe data messaging have been defined by ISO 22837 (Vehicle Probe Data for Wide Area Communications) and SAE J2735 (Dedicated Short Range Communications Message Set Dictionary). The SAE 2735 standard is most relevant to this report.

The SAE J2735 Message Data Dictionary¹ defines a probe data message frame and also defines a wide array of probe vehicle data. Specific to this report, a data element DE_VerticalAcceleration is defined representing the signed vertical acceleration in units of 0.02G over a range of +1.5 to -3.4G, plus provision for indicating larger negative values.

Data element DE_VerticalAccelerationThreshold provides for a preset threshold for vertical acceleration. When any one of the four wheels exceeds this threshold, a bit is set in a bit string within the data element framework. The standard notes that this element is intended to assist in identifying potholes and other road abnormalities.

A probe snapshot message is defined in the standard. This message consists of 42 data elements, including DE_VerticalAcceleration. Therefore the probe data message as defined in J2735 can provide useful data for the purposes of pavement assessment.

Current State of the Art in Probe Data²

Data Reporting

Data reporting occurs in the form of short messages which are time-relevant but not time critical. Transmission delays of several minutes or even more are acceptable for traffic and weather information, whereas safety information requires less latency. Pavement quality data is not as sensitive to message delays, since pavement deterioration occurs gradually.

Wireless transmission costs are a key component of deploying probe data systems. It is typically the frequency of the messages, rather than their length, which affects wireless airtime costs. Therefore exception-based reporting can be important for communications efficiency. By referencing an on-board database (which is updated as needed via broadcast), vehicles would only send messages when their own situation is different than information in the database. For instance, the database could contain a map of known potholes so that redundant data would not be sent.

Further, in a mature system in which the majority of vehicles are equipped to provide probe data reports, only a portion of them need to provide information for the overall situation to become clear in the data. Therefore, a communications management loop may be required to instruct on-board systems to temporarily cease reporting.

Data reporting can be accomplished through a wide variety of communication media, including cellular, cellular data, General Packet Radio Service (GPRS), DSRC, WAVE, and even 802.11a wireless hotspot technology. Where DSRC beacons are already common, such as in Japan for their ITS information system, DSRC is a good option and commercial airtime costs are not an issue since the system is operated by the government. In the commercial wireless

¹ SAE International J2735 Dedicated Short Range Communications Message Set Dictionary, revised 2009-11, available at www.sae.org.

² Bishop, Richard. *Intelligent Vehicle Technology and Trends*. Artech House, 2005. ISBN 1-58053-911-4.

arena, new cellular data services are under development which are expected to offer lower rate structures for probe data.

Probe Data Deployments

Probe data activities in Europe have led the way in examining business-viable approaches. Starting just after the turn of the century, the German firm DDG initially provided traffic information services based upon deployment of thousands of road-based traffic sensors. Via separate agreements with BMW and VW, they expanded to collecting probe data as well. As of 2005, approximately 70,000 FCD vehicles (close to 1% of total passenger cars in Germany) were reporting data, and DDG was processing 30M records daily from reporting vehicles. As a first generation system, the DDG approach was hampered by high communications costs, as vehicles reported at regular intervals whether data was needed or not.

In addition, the Global System for Telematics project, sponsored by the European Commission, conducted field trials of probe data collection in Paris, Munich, Gothenberg, Torino, and Russelsheim/Aachen during 2006 exploring new approaches to more efficient probe data reporting.

The BMW approach to second generation probe data systems, called Extended Floating Car Data (XFCD), is based on reporting by exception, data management, advanced event detection algorithms, and data cleansing. The key to exception reporting is the presence of an on-board data base which is frequently refreshed by new data. Although this data refreshment requires communications airtime, it can be transmitted in a broadcast mode which is much less costly. XFCD applications implemented by BMW during their research phase included traffic, weather (precipitation, visibility), and road conditions. Data elements collected include speed, acceleration, windshield wiper status, ABS signals, headlight status, and navigation data.

What are the necessary penetration rates of equipped vehicles for pavement assessment? Most analyses have focused on detecting traffic incidents, which provides a reference point for this question. BMW researchers have performed extensive analyses to understand the tradeoffs between the quality of traffic information and the necessary penetration rates of equipped XFCD vehicles. They assumed a period of 10 minutes for detection of a traffic incident, which they deemed to be satisfactory precision for reporting on traffic conditions. One factor affecting needed penetration rates is traffic volume. For example, mean passenger car volumes of 1000 cars/hour require penetration rates of 3.8% in order to reliably detect an incident (reports from at least 3 XFCD vehicles) within 10 minutes. The necessary penetration rates are halved if a 20 minute detection period is allowed. The researchers applied their methodology to the Munich road network as an example.

Results showed that, at a penetration rate of 9%, traffic conditions on 50% of the secondary network are detected. If only the primary network is analyzed, a penetration rate of only 5% is sufficient to cover 2/3 of that network. Overall, the analysis showed that an XFCD-capable fleet of 7.3% of the total number of passenger cars is sufficient to detect traffic conditions for over 80% of the main road network. For the overall German federal motorway network, analyses showed that penetration rates of at least 2% are required for good incident detection at peak traffic times, and that satisfactory traffic information can be generated on 80% of the motorway

network at penetration rates of around 4%. These results imply that for detecting more slowly changing pavement conditions, even lower penetration rates will be sufficient.

Currently, BMW vehicles in Europe report a GPS location every 1-2 minutes, based on a simple algorithm that prevents transmission when there is no relevant data to transmit. Later in 2011 their vehicles are expected to be equipped with XFCD, reporting speed and GPS location by exception -- when the vehicle detects something interesting it creates a burst of GPS points and sends them to BMW, which forwards this information on to their traffic data provider. This system also transmits other parameters such as fuel consumption, which is used for eco-routing. The current implementation does not transmit any other data i.e. data coming from the suspension system. However, BMW representatives noted that technically it would not be difficult to do so. The core issue would be establishing a business case to cover the cost of transmitting additional data.

While BMW has been a leader in this field, active work is also underway by other car companies. Probe data systems of the type described above are likely to enter the U.S. market in the 2011-2012 timeframe. Because the per-vehicle cost is relatively low once the vehicle becomes connected (for telematics purposes), such systems will spread fairly rapidly throughout the range of available models from many manufacturers. The communications medium for these probe data services will be cellular communications, which provides more than adequate technical performance. Cost for data will remain the pacing factor for the extent of deployment.

Related Work at UMTRI

In 2010 Michigan DOT contracted with UMTRI to provide a system to monitor slippery roads and road surface roughness based on probe data. They are using a Droid phone platform to collect vehicle data and transmit it to a backend server. The combination of the Droid platform interfacing with the vehicle OBD port is seen as an inexpensive approach to collecting basic probe data. Four kinds of data are collected:

- CAN messages
- external road surface temperature and humidity (added external sensors)
- GPS position
- 3-axis accelerometer data (from the Droid)

They will have two vehicles in service, driven by MDOT employees over a two year period. Data will be gathered, evaluated, archived and merged with data on the MDOT DUAP server. The team is working with an automaker to gain access to specific proprietary CAN data to enhance the dataset. The Auburn team coordinated with the UMTRI team in conducting this project, exchanging technical information and results.

III. System Development and Analysis

1. Methodology

This section of the report discusses the methodology behind the algorithms which have been developed and tested for assessing pavement quality from on board vehicle sensors. It should be

noted that there are other methods which can be used to estimate the IRI and location of potholes. The focus in this study was to develop methods which are easy to implement with little computational processing while still giving a reasonable prediction of IRI. The focus is to make the methods easy to implement in a PDPM for near term deployment.

Root Mean Squared

As the vehicle drives along a stretch of road, it experiences vibrations caused by the road surface. Generally speaking the vibrations experienced will increase on more rough roads and decrease on smooth roads. One of the methods for estimating the IRI of the road is investigating how these vibrations relate to the roughness of the road. In determining the vehicle vibrations it is desired to use directly measured sensors to reduce the overall processing requirements of the method. There are four sensors which currently exist in production vehicles which can directly measure the vibrations experienced by the vehicle. These sensors are the vertical acceleration, roll rate, pitch rate, and suspension deflection. The measurements from these sensors are generally time domain signals. Thus, in order to compare these signals to the IRI which is a scalar value, a scalar function is needed. The RMS of the signal is one such scalar function that can be used to describe the amount of overall vibrations in a signal.

The methodology that follows is written for the vertical acceleration measurement; however the same methodology is followed for each of the available signals. The RMS acceleration is calculated using the following equation,

$$a_{z,rms} = \sqrt{\frac{1}{n} \sum_{i=0}^n a_{z,i}^2}$$

This gives a scalar measure of how much variability there is in the vertical acceleration profile. Figure 1 shows the relationship between RMS acceleration and IRI for the quarter car model. Since this RMS acceleration is calculated from the same model used to calculate the IRI, this represents the best case scenario for matching the IRI with RMS acceleration. Although the trend is captured it can be seen that there are variations in the magnitude in some locations. Since the IRI is calculated from the accumulation relative suspension deflections we expect some variations between the IRI and the RMS vertical accelerations.

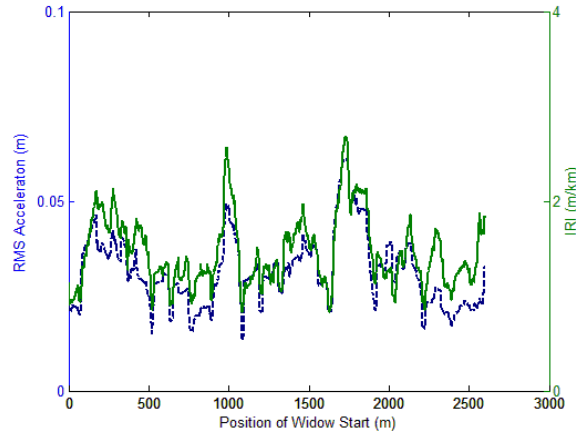

Figure 1- IRI compared to RMS Acceleration of quarter car model

Although the road over which the vehicle is driving does not change, the vibrations experienced by the vehicle will differ quite significantly based on the velocity at which the vehicle is traveling. If a vehicle is traveling slowly over a bumpy road the vibrations experienced will be lower than if it is driving at a higher speed. As the vehicle speed changes the frequency of the road inputs to the wheels also increases. When this frequency exceeds the bandwidth frequency of the suspension the vibrations caused by the road will be attenuated. Since the probe vehicles will be traveling at various speeds, it is important that the RMS accelerations are compensated to account for the variability in vibrations due to speed. The compensated acceleration can be determined by dividing each of the acceleration values by the longitudinal velocity, resulting in the following equation.

$$a_{z,comp} = \sqrt{\frac{1}{n} \sum_{i=0}^n \left(\frac{a_{z,i}}{v_{x,i}} \right)^2}$$

Figure 2 shows RMS vertical acceleration for multiple laps at 40, 50 and 60 mph. The RMS was taken for a sliding window of data for the longitudinal length of the track. Before compensation (a) it can be seen that at higher speeds the RMS vertical acceleration values are increased. When using the compensated method (b) all of the RMS vertical accelerations occur on the same scale. This allows one to directly compare the values from vehicles traveling at different speeds. It should be noted that the speed in these plots is the targeted speed. The actual speed from the experiment varied two to three MPH above or below the targeted speed. The speed used for the normalization is the actual speed at the instance at which the vertical acceleration measurement is taken.

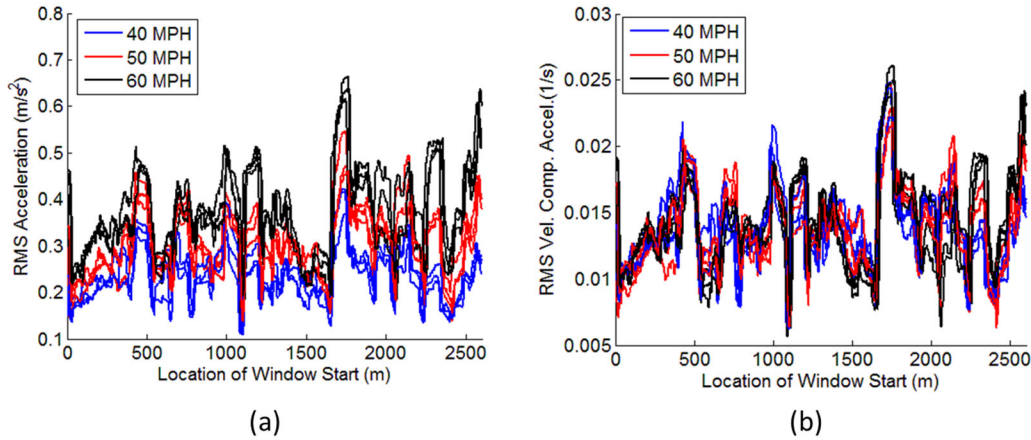

Figure 2 - (a) RMS vertical acceleration for vehicle at various speeds (b) Normalized RMS vertical acceleration for various speeds

It must also be considered that the suspension characteristics of the probe vehicles will be different which will cause the compensated RMS vertical accelerations for a given road section to vary for different vehicles. The velocity compensated RMS vertical acceleration for a given vehicle can be scaled to closely match the IRI for a section of road, yet the necessary scaling will be vehicle dependent. In order to map the RMS vertical acceleration to the IRI for a given vehicle, the vehicle must be driven over a section of road with a known road profile and IRI. By averaging the quotient of the two signals for each window, the appropriate scaling to the IRI can be determined. It is advantageous for multiple runs to be averaged together to most appropriately determine the mapping from the RMS vertical acceleration to the IRI. This same methodology can be used with similar results for the roll rate, pitch rate, and suspension deflections. The effectiveness of this method is demonstrated in the next section of the report.

Suspension Energy

The suspension deflection measurements can be used in other ways which allow other scalar metrics to be used which can predict the IRI for a road section. One logical method for such a method is to use the energy which is present in the suspension. This energy can be determined from the suspension deflections and knowledge of the parameters of the vehicle, namely the un-sprung mass and the spring constants. The total energy in the suspension will be a sum of the kinetic and potential energies of the suspension as shown in the following equation

$$E_{sus} = \frac{1}{2}kx^2 + \frac{1}{2}m_u\dot{x}^2$$

where k is the spring rate of the suspension, x is the measured deflection, and m_u is the un-sprung mass of the suspension. The total energy of the suspension system can then be determined by summing the suspension energy for all four corners of the vehicle. This total suspension energy is a scalar function which can be related to the IRI in a similar manner as the RMS methods, by calibrating the scaling to the vehicle and mapping the measurement to the estimated IRI value. It should be noted that this method requires numerically differentiating the signal from the deflection sensor. Thus, there is an extra level of processing required in this method compared to the RMS methods.

Pseudo IRI

The IRI is calculated by accumulating the suspension deflections of a quarter car model with specific vehicle parameters over a road profile. The accumulated value is then divided by the length of the profile over which the model was simulated. Considering a real vehicle equipped with suspension deflection sensors a similar method can be used to determine a “pseudo IRI” which will have a similar behavior as the quarter car model over a given road section. Ideally with a perfectly modeled vehicle the pseudo IRI would match perfectly with the true IRI, however many assumptions are made in the quarter car model which prevent this from being true. With this method as with the others, it is required that the pseudo IRI for a given vehicle is calibrated to the actual IRI. The pseudo IRI can be determined by the following expression.

$$PIRI = \frac{1}{L} \sum_{i=1}^{N-1} abs(x_{i+1} - x_i)$$

where x is the measured suspension deflection and L is the length of profile over which the vehicle has driven. Since the IRI is typically reported as the average of the left and right profiles the PIRI is calculated for the right and left side of the vehicles. Assuming the front and rear wheels follow the same path it only needs to be calculated for the front or rear of the vehicle.

Pothole Detection

Sigma Threshold Algorithm

The detection of potholes or large bumps in the road can be determined by identifying spikes or anomalies in the measured vibration signal. In this work two algorithms are presented which can effectively identify these anomalies. The first algorithm will be referred to the sigma threshold method. This is a very simple algorithm which requires taking the standard deviation of the signal and searching for values which are above a certain threshold which is a scaling of the standard deviation of the signal. The potholes will then be given by,

$$find\ i : \{abs(a_{z,i}) > K * \sigma_a\}$$

where σ_a is the standard deviation and K is a scaling of the standard deviation. i are the indices of the vector of data which meet the condition. Varying K will determine the selectivity of the algorithm. This searching algorithm can be easily implemented in a ‘for’ loop with a logical check to determine if the condition is met. The spatial location of the signal must also be tracked to determine the location of the bump or pothole.

Wavelet Transform Algorithm

At the cost of more computational expense a more sophisticated algorithm based on the Wavelet transform can be implemented. Wavelets are functions that decompose a signal into different frequency components and then analyze each frequency with a resolution matched to the scale being analyzed. The wavelet transform is based on the same premise as the Fourier transform. However instead of representing the signal as a superposition of sines and cosines it represents the signal as a superposition of a function called a mother wavelet. There are several mother wavelets which can be used to perform an analysis. For a mother wavelet ψ , the scaling and translation are described by,

$$\psi_w(b, a) = \frac{1}{\sqrt{a}} \psi\left(\frac{x-b}{a}\right)$$

where a and b relate to the scaling and translation of mother wavelet respectively. The coefficients of the wavelet can then be determined using the following expression,

$$C_{b,a}(x) = \int_{-\infty}^{\infty} f(x)\psi_w(b, a)dx$$

The implementation of the two dimensional wavelet transform in this work was done using the discrete wavelet transform ('dwt') command in Matlab. The 'haar' mother wavelet was chosen since it is effective at representing bumps in the acceleration profile. The function returns the coefficient matrix for the acceleration profile being analyzed. The coefficient matrix can then be analyzed in a method similar to the sigma threshold algorithm to determine the locations of the potholes. This algorithm is able to identify other features which unique to the signal, the sigma threshold algorithm might miss. Thus for a given scaling of the threshold more locations are identified as anomalies.

Experimental Test

Experimental tests were conducted at the NCAT test track shown in Figure 3. The track is approximately 2750m long. For the purpose of this analysis the track was divided into four sections, two straight sections and two curved sections. Since the oval track has sharp turns which are banked, the data from the straight sections was used to represent a typical passenger vehicle road. The 3rd Quarterly report discussed how the sharp turns in the corners can cause a bias in the estimation of the IRI. The test vehicle chosen for this work was an Infiniti G35 sedan. The vehicle was driven around the track for four laps at varying speeds collecting data from GPS, IMU, and Suspension deflections. A Novatel Propak-v3 GPS receiver was used to track the position of the vehicle along around the track and ultimately relate the vehicle sensor measurements to the IRI values which were measured. In order to ensure accurate positions for comparison with the road profile, a RTK system was used. A Crossbow 440 IMU mounted in the center console was used for measuring the vehicle body accelerations and rates of rotation. The Crossbow is an automotive grade sensor which has similar specs to that which might be found on a production vehicle. To measure the suspension deflections Celesco linear potentiometers were mounted on each corner of the vehicle parallel to the struts, to measure the linear deflection of the strut. Additionally the steer angle and wheel speeds were logged from the vehicle's CAN bus. The data was then post processed using algorithms written in Matlab. The truth IRI data for the track was collected using a van equipped with an ARAN Laser profilometer shown in Figure 4. A reference point at the start of the east curve and end of the south straight was used to ensure the measured IRI data was properly aligned with the collected vehicle data. Based on the method it is estimated that the longitudinal location of the data is aligned with approximately a meter of accuracy.

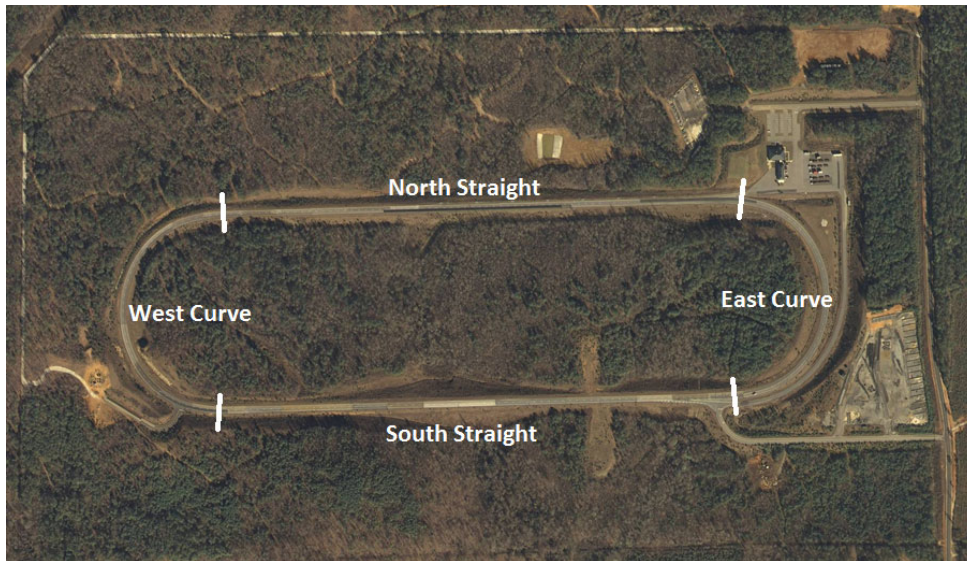

Figure 3 – National Center for Asphalt Technology test track



Figure 4 – NCAT van equipped with laser profilometers

It was determined that when performing the road roughness analysis it is beneficial to use a sliding window rather than splitting the track into discrete windows. The sliding window allows for a continuous IRI measurement to be tracked which is beneficial for establishing trends. Figure 5 shows the mean roughness index (MRI) for the south straight of the track for various sliding window sizes as a function of the window start location. It can be seen that when using smaller windows the variation in the MRI is higher, while the larger window size tends to smooth the measurement by averaging the values together. For analysis of the IRI estimation methods, the mean value of these three runs is used as the true IRI value. It should be noted that

the MRI is simply the mean of the right and left wheel path IRIs. In the remainder of this report the IRI on the plots shown is the MRI.

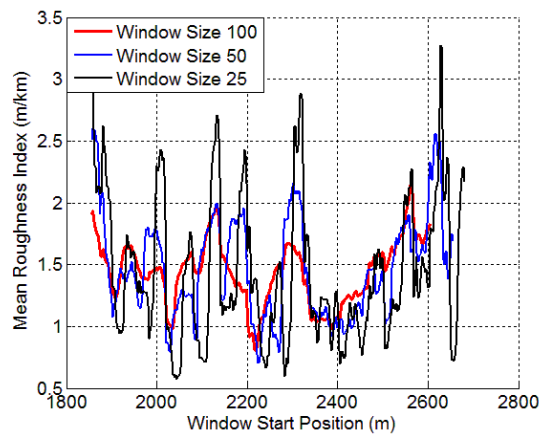

Figure 5 – MRI for south straight for various window sizes

Experimental Results

IRI estimation

Presented in this subsection are the results from the experimental tests using the methods described in the methodology section to estimate the IRI of the track. The sliding window method was used for all of these analyses to allow the trends between the true IRI and the estimated IRI to be investigated for each method. The results presented here were for the south straight, but the trends found for the south straight were consistent for the north straight as well. It should also be noted that the true IRI in each of these plots is the mean of three measurements of the MRI. The algorithms were run for both a 25m and 100m sliding window to understand the effect of window size on the results.

The vibration of the vehicle body in the vertical translation, pitch rotation, and roll rotation can be compared to the IRI. Figure 6 shows the estimated IRI using the RMS vertical acceleration compared to the measured IRI values. The estimate of IRI is the mean of four passes on the south straight of the track. It can be seen that there is a strong correlation between the estimated IRI and true IRI using this method. The trend is captured exceptionally with some deviations in magnitude in certain locations. This is expected since the vertical vibrations are the principle motion caused by the road roughness and the IRI was developed specifically to capture the vertical vibrations. The error is zero mean for both window sizes and smaller in magnitude for the 100m window than 25m window. Figure 7 and Figure 8 show the estimation of IRI using the RMS pitch rate and roll rate respectively. The pitch rate method is effective in capturing the trend of the IRI, although the magnitudes do not always match. Although intuitively the roll rate should be excited by the road roughness, it is much less effective in capturing the trend of the IRI. It is hypothesized that this is caused by changes in the phases of the right and left wheel profiles. If the profiles are out of phase extra vibration is caused in the roll mode of the vehicle motion, if the profiles are in phase it causes less excitement in the roll mode. These effects are averaged out in the vertical displacement mode of the vehicle motion. It is possible that RMS roll

rate could stand alone as a separate roughness metric, although it can be corrupted by turning of the vehicle. The RMS pitch rate method seems to capture the trend of the IRI better since the profiles used to calculate the IRI are longitudinal.

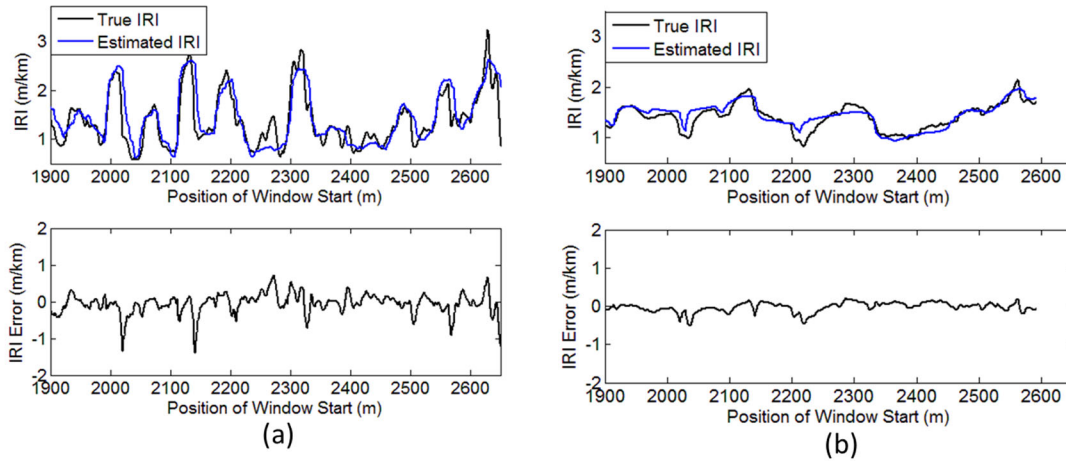

Figure 6 - Predicted IRI with scaled RMS vertical acceleration vs. measured IRI for (a) 25 meter window (b) 100 meter window

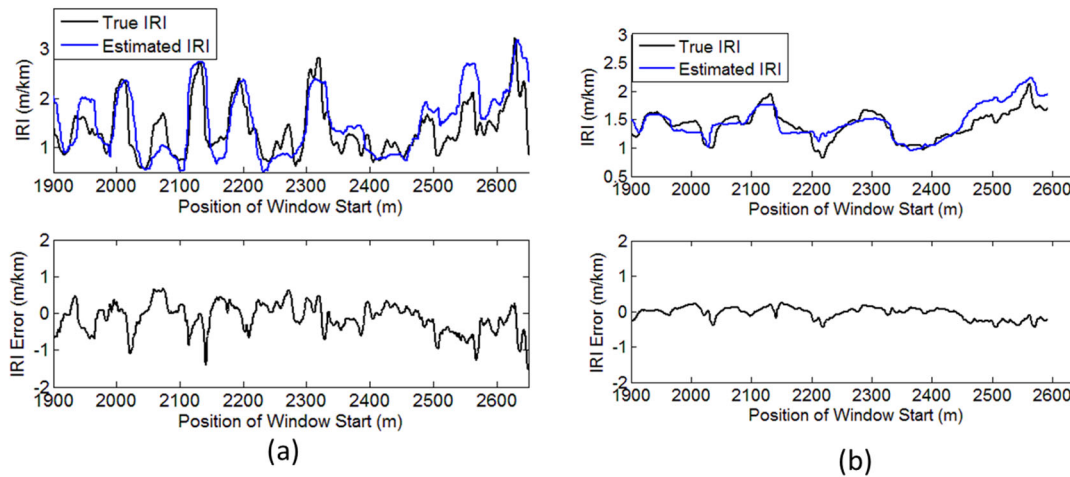

Figure 7 - RMS pitch rate estimated IRI compared to measured IRI for (a) 25 meter window (b) 100 meter window

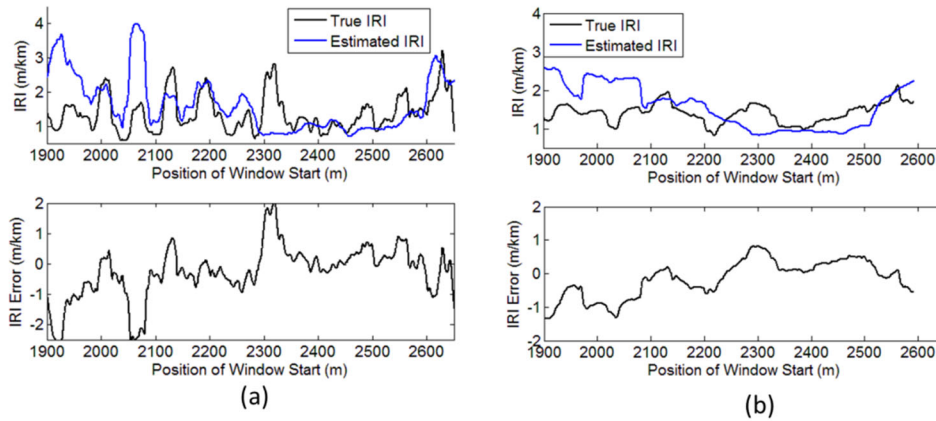

Figure 8 – RMS roll rate estimated IRI compared to measured IRI for (a) 25 meter window (b) 100 meter window

It is logical to assume the motion of the suspension should have a direct correlation to the roughness of the road over which the vehicle is traveling. Figure 9 shows RMS suspension deflection estimated IRI compared to the measured IRI. Again here the estimate is the average of four runs over the surface. It can be seen that the RMS suspension deflection method captures the trend of the IRI data well, although there are some areas where the estimate deviates. The estimated IRI using the suspension energy method is shown in Figure 10. The suspension energy method does not capture the IRI trend as well as some of the other methods, although it certainly does give some information regarding which road sections are rougher than others. Figure 11 shows the pseudo IRI method of estimating the IRI. This method captures the IRI trend very effectively, and it can be seen that the error is levels are similar to those with the RMS vertical acceleration method. With this method there are some areas where the estimated IRI deviates from the measured value, as seen with the other methods.

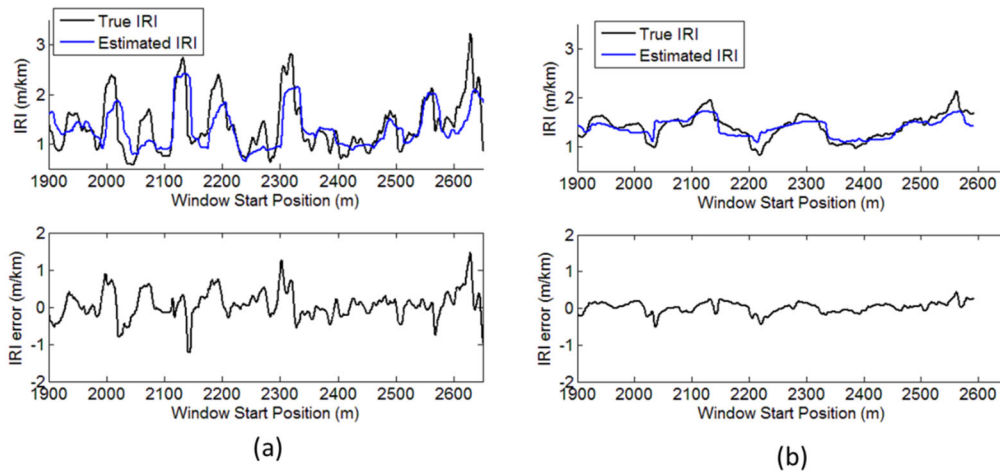

Figure 9 – RMS suspension deflection estimated IRI compared to measured IRI for (a) 25 meter window (b) 100 meter window

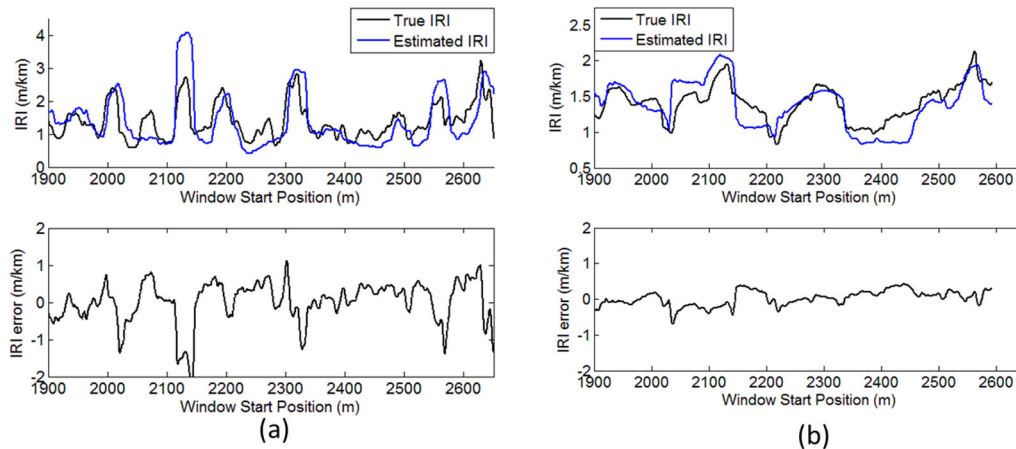

Figure 10 – Suspension Energy estimated IRI compared to measured IRI for (a) 25 meter window (b) 100 meter window

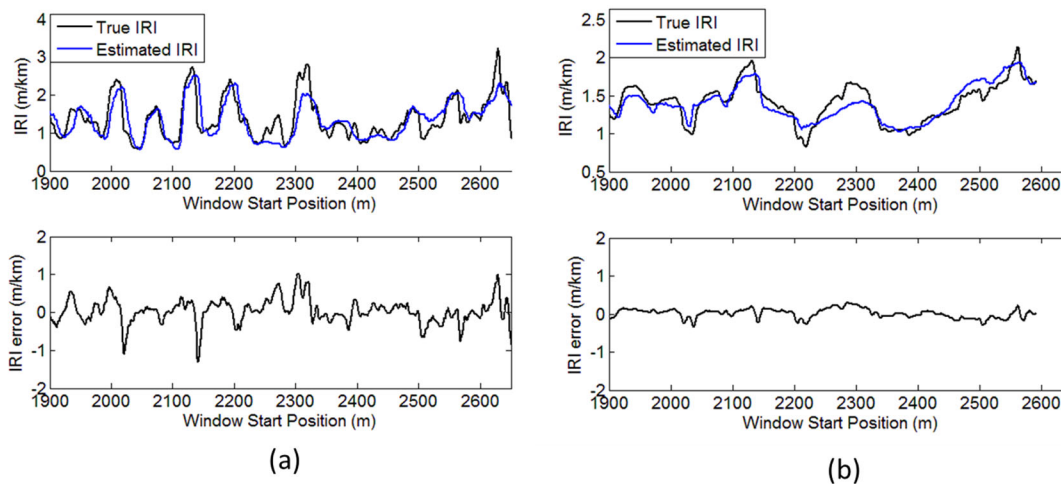

Figure 11 – Pseudo IRI estimated IRI compared to measured IRI for (a) 25 meter window (b) 100 meter window

Table 1 summarizes the RMS errors given in m/km for the each of the methods which were tested for three different window sizes. Studying the table it can be seen that the error increases with decreasing window size. The larger window sizes result in more averaging of the deviations along the signal resulting in a more consistent estimate of the true IRI. Thus it is recommended that larger windows should be used when possible to assure the most accurate IRI estimates. Also based on this analysis it can be concluded that the RMS vertical acceleration and Pseudo IRI methods are the most effective methods followed closely by the RMS suspension deflection.

This is to be expected since the IRI was developed specifically to capture the vertical acceleration experienced by the body of the vehicle and is calculated from the vehicle model's suspension deflections. The error analysis allows the problem to be inverted to investigate how accurately the IRI can be estimated with a given method. Consider the standard deviation of the error which is generally numerically similar to the RMS error. The standard deviation of the error for the RMS vertical acceleration method for a 100 m window size is 0.123 m/km. This means that assuming the error is Gaussian it can be said with 95% confidence that the actual IRI measurement will be within +/- 0.246 m/km of the estimated IRI.

Window Size	IRI Estimation Method					
	RMS Vert. Accel	RMS Pitch Rate	RMS Roll Rate	RMS Susp. Def	Susp. Energy	Pseudo IRI
25 m	0.309	0.449	0.957	0.427	0.592	0.352
50 m	0.217	0.292	0.884	0.262	0.353	0.221
100 m	0.126	0.177	0.676	0.143	0.215	0.121

Table 1 – RMS error (m/km) for the various estimation methods for different window sizes

Pothole Detection

In addition to estimating the IRI of the roadway it is also desirable to identify and locate potholes or bumps in the road. The pothole detection algorithms were run on both the vertical acceleration data and the suspension deflection data. Figure 12 shows the magnitude of the vertical acceleration and suspension deflection at the locations which have been identified as bumps using sigma threshold algorithm and the wavelet transform algorithm with a threshold of six times the standard deviation of the signal ($K = 6$). This threshold can be adjusted to give the algorithm a higher or lower level of discretion in identifying bumps. It can be seen that the sigma threshold algorithm identifies fewer points as bumps when compared to the wavelet transform algorithm. The sigma threshold algorithm also picks the same locations with the vertical acceleration and the suspension deflections, while the wavelet transform algorithm identifies more locations as bumps in the suspension deflections.

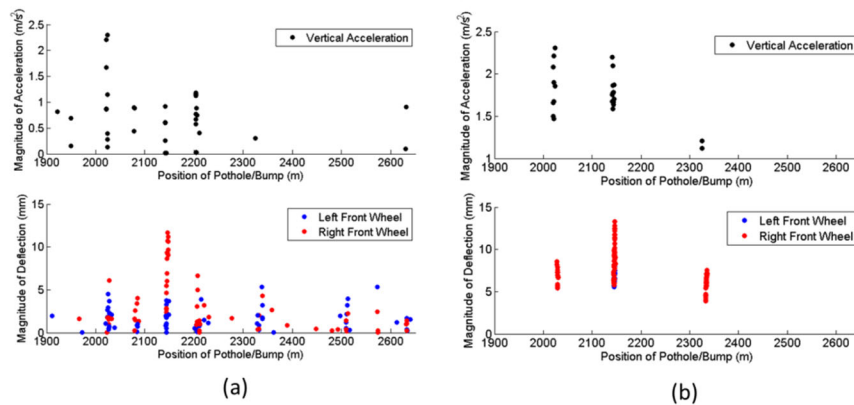

Figure 12 – Pothole locations using a 6σ threshold with (a) Wavelet Transform Method (b) Sigma Threshold Method

It should be noted that the wavelet transform algorithm returns the values which are statistically unique from the surrounding values, while the sigma threshold algorithm returns values which are statistically unique to the entire signal. Thus if the overall roughness as determined by the acceleration profile is lower it will take a relatively smaller acceleration to register as a bump as compared to an acceleration profile which has more variability. It should be noted that several of the bumps identified on the NCAT track are the transitions between track sections, not what would traditionally be classified as potholes. However, the algorithm would be just as effective for detecting potholes on roads which are otherwise smooth. If the road was very rough it would be difficult for the algorithm to detect a pothole from the general roughness of the road. Figure 13 is shown to demonstrate the effect a bump in the acceleration profile can have on the IRI estimation. The top of the plot is the estimated IRI using the RMS vertical acceleration method and the bottom of the plot are the locations of the potholes identified. It can be seen that the spikes in the vertical acceleration profile caused by the bumps in the road cause the IRI estimate to be higher than the true value.

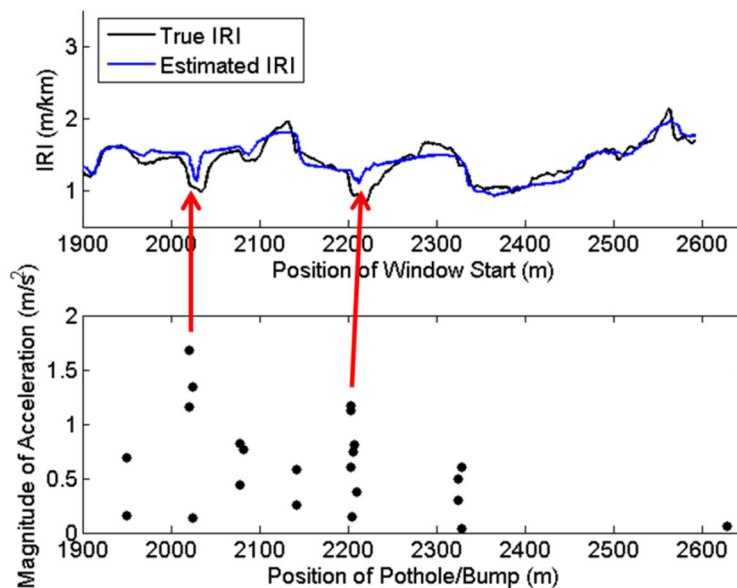

Figure 13 – Effect of Bumps in the road on estimate of IRI

Considerations and Recommendations

The primary purpose of this study was to develop methods which can be easily calculated and implemented in the PDPM system. It is recommended that the RMS vertical acceleration method is used as the primary means for IRI estimation. This method can be supplemented with the Pseudo IRI method if a vehicle is equipped with suspension deflection sensors. One of the main issues that must be addressed in the implementation of these methods is calibrating the vehicle dependent scaling which requires driving the vehicle over a known IRI section. There are several potential options for identifying this scaling factor for the vehicle:

- The vehicles could be calibrated from the factory

- Certain sections of the road way can be measured and used to calibrate vehicles as they pass
- Vehicle models with the vehicle parameters can potentially be used for the calibration
- The scaling could be determined for various vehicle classes

It is fortuitous that the two most effective algorithms are also two of the easiest and least computational expensive to implement. Thus they could be calculated in real time on board the vehicle, or the raw data could be passed at certain locations and post processed. For the pothole detection it is recommended that the sigma threshold method is implemented since it is less computationally expensive and tends to yield a very stable reliable result.

IV. Prototype System Design

This section describes the hardware and communication set up for the prototype PDPM system. The test vehicle used in the prototype system is a 2007 Infiniti G35 sedan shown in Figure 14. The vehicle is equipped with a Novatel Propak v3 GPS receiver, Crossbow 440 IMU, and Celesco CLP Linear Potentiometers shown in Figure 15. In addition to the external sensors, the wheel speeds and steer angles were also read off the vehicle's CAN bus. The sensors were interfaced to a PC in the car using custom software which was based on the Mission Oriented Operation Software (MOOS) platform.



Figure 14 – Prototype system test vehicle 2007 Infiniti G35 sedan



Figure 15 – Hardware used in prototype system (Left) Novatel Propak-v3 GPS receiver (Center) Crossbow 440 IMU (Right) Celesco Linear Potentiometer

Figure 16 shows a potential architecture of the PDDM system with the algorithm processing occurring off-line. This model would require sending the raw data via DSRC to a base station or processing center where the algorithms can be run to assess the pavement quality. In this architecture computational power is not an issue for running the algorithms. The only consideration on the vehicle computer needs to be the preprocessing and storage of data. There could potentially be a bandwidth issue associated with sending the raw data over DSRC if the vehicle is driving past a base station. Since the information is not safety critical it can be passed when the vehicle is at rest for example at a traffic light.

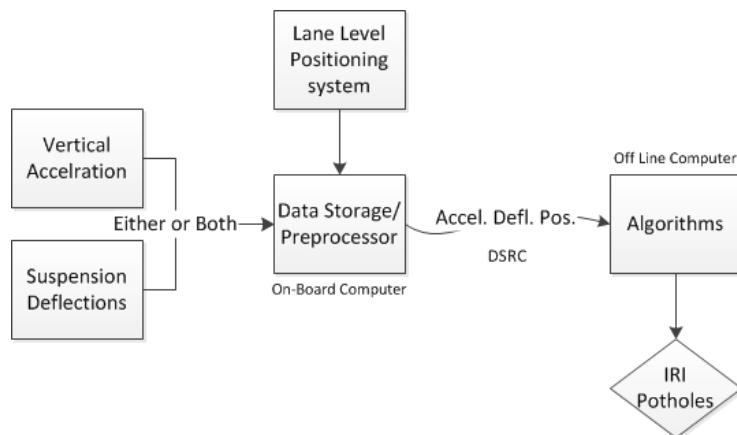

Figure 16 – System architecture for off-line processing

Figure 17 shows the architecture which would be used for an on board vehicle processing system. This method would necessitate a few changes in the implementation of system. The algorithms must be written to be processed in real-time and the vehicle computer must have enough processing power to run the algorithms. In this scenario, the vehicle is passing its estimates of IRI and locations of potholes via DSRC rather than its raw data.

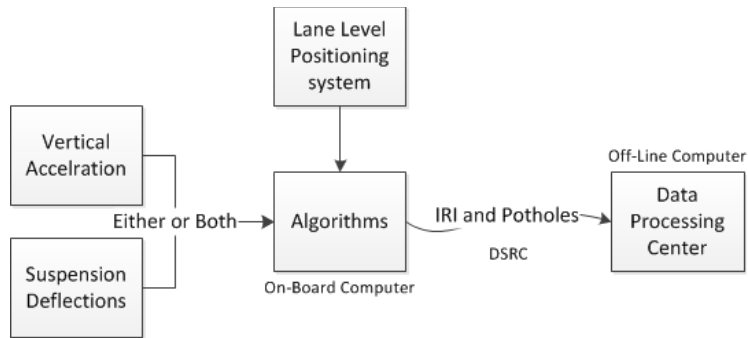

Figure 17 – System architecture for on-board vehicle processing

To better understand the ability for the required data to be sent via DSRC, a couple of simple experiments were run using two Kapsch MCNU with DSRC radios. One experiment tested the bandwidth of the radios to determine how long it would take to send a given amount of data. A set of IMU data equivalent to one lap around the track (2700m worth of data) was sent from one unit to the other, and the time of transmission was observed. It took more than 20 seconds for the data to be transmitted. Therefore at highway speeds (26m/s or 60mph) the vehicle would travel over 500m before the data transmission was complete. The other experiment tested the effective range of the DSRC radios. Data was sent from one radio to another and one vehicle was driven away slowly until data packets began getting lost. Kapsch advertises 1000m range with their DSRC radios, however in the tests conducted the effective range without losing data packets is closer to 700m. These tests were done in ideal conditions with direct line of sight between the vehicles. These results were somewhat expected since DSRC is intended for sending snapshots of data rather than continuous streams of data. Thus, the most effective method of implementation for PDPM is to have the algorithms processed on the vehicle and the IRI values and pothole locations to be sent as one short message. This will minimize the wireless data flow and potential loss of information.

V. Concept of Operations

Factors relating to a Concept of Operations are provided here. This structure is based on the format for ConOps documents used by CAMP.

1. Purpose of the System

The purpose of the PDPM system is to collect information from production passenger cars which can be processed and related to the quality of pavement, specifically pavement roughness. Furthermore, to detect and map pothole locations.

2. Vision of Pavement Maintenance Using Vehicle Probe Data

Current methods of assessing pavement quality rely on specially equipped vans which drive the roads and collect lane-level data as to roughness and potholes. This work is funded by state and local governments. It is a costly process with an inherent time delay between the start of deterioration and detecting it for remediation.

The vision of PDPM is to collect pavement-relevant information on a daily basis covering all roads using vehicle probe data. This includes a method to interpret raw data so as to provide

pavement assessments at a level approaching the quality of IRI measurements. A more advanced version of PDPM would be able to activate reporting of pavement-relevant information in specific geographic areas (or specific segments of road) and during specific timeframes. PDPM users would also be able to set thresholds for vehicle parameters so as to be able to adjust the sensitivity of reporting.

Further, having accurate and up-to-date pothole data will enable in-vehicle systems to warn drivers of upcoming potholes on a lane-specific basis, increasing safety and reducing the effect of these potholes on traffic flow. Basic systems would provide advisories on a road-specific basis, and more sophisticated systems would provide advisories on a lane-specific basis.

3. Assumptions and Constraints

For purposes of this document, a timeframe for initial operations is set for the 2015.

Assumptions

1. PDPM will use commercial wireless communications as its enabling communications media.
2. The initial PDPM deployment is targeted toward passenger vehicles. Passenger vehicles include light trucks and sports utility vehicles (SUVs). This group of vehicles is also called “light duty vehicles.”
3. Not all vehicles will have PDPM capabilities.
4. Vehicles equipped for PDPM will have at least “which road” positioning accuracy and ideally “which lane” accuracy.
5. The PDPM system will not interact with the driver.
6. The PDPM implementation will be compliant with the National ITS Architecture.

Constraints

1. Messaging standards will define the format of the data reported, specifically the SAE J2735 Probe Data message standard.

Legal Boundaries

Any violation enforcement actions at related to probe data information is outside the scope and boundaries of the PDPM system.

Privacy

Privacy issues associated with data used by the PDPM system are outside the boundaries of the system.

State and Local Government Policy and Legislation Affecting PDPM Deployment

Any legislation necessary to deploy PDPM is outside the boundaries of the system.

Non-PDPM Equipped Vehicles

Non-PDPM equipped vehicles are outside of the boundaries of the system.

4. User-Oriented Operational Description

This section was developed based on expert knowledge within the research team. It should be circulated amongst stakeholders for expansion and validation.

PDPM Users

Users of PDPM include the organizations, agencies, and individuals that are necessary for installing, maintaining, operating, and interacting with a functioning PDPM system. The primary users of PDPM are:

- Automobile OEMs – responsible for original equipment, and for vehicle-related equipment and software actions necessary to establish and maintain the in-vehicle PDPM system.
- State and local governments and their DOTs – responsible for applying the reported information to pavement management programs
- FHWA – responsible for developing high level guidance to state and local agencies in the deployment and operation of PDPM systems.
- Vehicle drivers – responsible for enabling data reporting from their vehicles; participation in data reporting is voluntary
- Data Providers – responsible for assimilating raw pavement quality data to define IRI values for specific sections of roadway, and distributing this data to end users.
- Standards Organizations -- responsible for maintaining and updating data dictionaries and message frames for probe data.

Automobile OEMs

Automobile OEMs may incorporate their role into existing organizational structures. There are additional roles that they will assume to help ensure that PDPM remains in operation over the long-term. These include:

- Development of standards and certification procedures
- Maintaining the effectiveness for PDPM as hardware and software are upgraded in new vehicle designs

State and Local DOTs

State and local DOTs have the primary role as end users of pavement quality data. They may process raw data themselves if collected via DSRC-based RSEs, or they may purchase data from Data Providers. Their roles include:

- Maintain RSEs for reliable operation (when used)
- Installation of backend connectivity from roadside equipment to Data Centers, if needed
- Participation in standards development activities

FHWA

FHWA may incorporate its role into its existing organizational structures. There are additional roles it may assume to enable the success of a nationwide deployment of PDPM. These roles include:

- Development of guidelines to assist state and local agencies in the installation, operation, and maintenance of PDPM systems.
- Development of training materials and training courses related to PDPM operation, and maintenance.
- Participation in joint working groups and standards activities to continually assess stakeholder needs with respect to PDPM, particularly as a bridge between car-makers, data providers, and state and local agencies

Drivers

The data collection aspect of the PDPM system is invisible to the driver. The driver benefits from this data indirectly by enjoying better maintained roads. The driver can also benefit directly, if the car-maker or wireless device applications providers implement applications to advise the driver of upcoming potholes.

Data Providers

Data providers currently exist to provide traffic, weather, and other data to a wide variety of users. They also receive data from a wide variety of sources, including vehicles transmitting data via commercial wireless services. To participate in PDPM operation, their roles would include:

- Assimilate raw pavement-relevant data to provide IRI ratings keyed to specific road segments
- Participation in national working groups and standards activities to continually assess customer needs with respect to PDPM and work with car-makers to meet those needs
- Develop affordable data packages for state and local agency customers

Standards Organizations

Standards organizations serve a key role in ensuring the data transmitted, regardless of vehicle type, is consistent and sufficient for the PDPM system requirements. Their roles include:

- providing a committee structure to monitor and update standards relevant to PDPM
- convening the car-makers, state and local agencies, and data providers to periodically update the standards

5. Relationship to National ITS System Engineering Architecture Update

The USDOT ITS Joint Program Office is currently conducting a system engineering process to update the national ITS Architecture to encompass developments in cooperative systems.

This activity has defined a Core System Concept of Operations and will be defining the Core System's requirements and architecture. Based on discussions with the contract team, the collection of probe data from mobile devices is seen as an application that would lie outside of the Core System. The Core System would provide a service to tell a prospective data provider where to send data. This may be directly to the Core System, where it will be used as an input to

a publish and subscribe data distribution mechanism, or it may be directly to a data collector on the other side. The actual implementation would depend on local policies and the capabilities of the local Core System.

VI. System Requirements

1. Vehicle

- vehicle must be equipped with a positioning system, including a location processor, of sufficient accuracy that enables the pavement-relevant data to be lane-matched to specific road segments
- vehicle must be capable of real-time geo-location and geo-logging of data
- vehicle must be equipped with vertical accelerometer(s) mounted on the chassis or suspension deflection sensors
 - The sensors must be sampled at greater than 20Hz (preferably 100Hz)
- vehicle must be equipped with a databus sufficient to route sensor data to a pre-processor
- vehicle must be equipped with a pre-processor which:
 - runs software to convert sensor data to IRI estimates
 - can run in event-based mode, reporting only when certain thresholds and other conditions are met
- vehicle must be equipped with a data communications subsystem capable of transmitting and receiving data wirelessly
- data communications subsystem must be capable of transmitting data only within specific geographic boundaries and timeframes, as commanded by the data provider
- DSRC operation
 - vehicle must be compliant with all current Connected Vehicle standards
 - IEEE 802.11p, J2735 message set, J2945 performance spec, IEEE 1609 security standards, etc.
 - vehicle must be equipped with a WAVE radio and antenna, capable of broadcasting and receiving at 5.9 GHz

2. Data Provider

- the data provider (typically contracted by one or more car OEMs to aggregate and process probe data and distribute it to a variety of customers) shall receive pavement-relevant probe data from equipped vehicles
- the data provider shall aggregate pavement-relevant probe data and reference the pavement quality information to the road network (either raw data or event-driven data)
- the data provider shall provide a means for the data customer to specify reporting for specific geographic areas and timeframes
- the data provider shall provide a means to manage vehicle reporting, in terms of specific geographic areas, timeframes, and sensor thresholds

3. State/Local DOT

- the DOT must maintain a means to receive reported PDPM data
- the DOT must maintain an electronic road database upon which pavement quality data can be overlaid
- (DSRC Option) the DOT must operate and maintain RSEs to receive probe data

4. Operational Needs

The following are the operational needs for PDPM:

- PDPM needs to function in all weather and lighting conditions.
- PDPM needs to perform effectively in urban, suburban, and rural areas.
- PDPM needs both in-vehicle and infrastructure self-diagnostic tools that allow the system to take itself off-line in case of malfunctions.
- PDPM needs to report the off-line status of any of its components to the owner/operator of that component if and when that component takes itself off-line as the result of a self-diagnosed fault.
- PDPM should have a high degree of reliability and availability.
- PDPM communications need to have sufficient communications security to ensure the authenticity of all its messages.
- PDPM system upgrades need to be backwards compatible with previous versions of the PDPM system.
- PDPM needs to be positionally accurate enough to enable pavement-relevant data to be correlated with specific lanes on specific roads

VII. Deployment risks, constraints, opportunities

This section provides an examination of the risks, constraints, and opportunities in large scale deployment of using vehicle-based probe data for pavement maintenance. Operational scenarios are discussed, followed by an examination of the business case. The section concludes by specifically examining risks, constraints, and opportunities.

1. Operational Scenarios

Two types of operational scenarios are discussed here. One concerns the wireless media used and the other concerns data management. The wireless media used and the data management approaches are independent, therefore any combination is feasible.

Wireless Media

Two types of wireless media are discussed here: commercial wireless services (i.e. the cellular phone network) and DSRC. With commercial wireless services, the vehicle transmits through the widely available cellular communications network to report data to the data provider. For instance, this is the way vehicle diagnostics and other information flows on the GM OnStar system, automotive telematics systems in general, and probe data services in Europe. Initial probe data services to be introduced into the U.S. will use this approach as well. With DSRC, the vehicle stores data in an on-board buffer and takes advantage of V2I communications to transmit

the entire dataset to an RSE when one is encountered. The information is then routed through the backhaul network to an entity which performs the processing. Which is the better approach? Several pro's and con's can be examined.

Commercial wireless services are available now and they provide sufficient bandwidth and communications latency for probe data (unlike safety applications, probe data is not affected by typical data communications delays of a few seconds). However this bandwidth must be paid for. By contrast, DSRC-based communications are “free” to use once they exist, but RSEs will have to be installed and maintained by DOTs. To do so only for probe data may not be cost effective; however, if RSE's are installed for other purposes (for instance, transmitting SPAT data from traffic signals) then the DSRC link could provide a channel for probe data. The DOT could take on the task of assimilating the data for their pavement management program, or forward the data to a data provider for processing. Using the DSRC approach, data collected by the vehicle is held until the vehicle encounters an RSE. If RSEs are not available in rural areas, then cellular transmission of data is the only viable option.

First generation probe data systems are expected to be operating within the U.S. in the next few years, coming before DSRC roadside units are available in significant numbers. The first probe data systems will build on the European approach of commercial wireless services. Therefore, first generation probe systems should be viewed as using commercial wireless services.

Data Management

Developers of probe data systems in Japan and Europe have defined Probe Data Management, which implements a “back channel” to vehicles via broadcast, instructing vehicles within a certain region to increase/decrease reporting frequency, increase/decrease reporting accuracy, or report data only when the vehicle is within a specific geographic area. Therefore, in areas in which a DOT is interested in detailed pavement data, a future probe data center could use the probe data management technique to focus reporting on a particular road section. Conversely, if the quality of particular roadways is well known, vehicles can be instructed not to report pavement-relevant probe data, conserving communications bandwidth.

If nothing of note is happening on the roadways, why use communications resources to report it? This is the thinking behind event-based probe reporting, which is used in European implementations and is likely to be used in the U.S. by at least some auto-makers. Rather than collecting and reporting raw probe data continuously, the vehicle pre-processes the data to flag pre-defined “events.” Typical events in existing systems include traffic jam, slippery road, potholes, and weather events. Probe Data Management can be used to set thresholds of reporting, such as a specific vertical acceleration value to detect certain types of potholes.

The idea behind PDPM is to gather data for all roads in order to create an IRI map of these roads. This is a case in which continuous data reporting is needed. However, once a baseline is created, event-based probe reporting can be useful to detect changes in pavement quality.

2. Business Case Considerations

Cars are sold on a national basis and the car-maker requires consistency in the software for probe data reporting across their fleet. If they are transmitting a packet of probe data for pavement quality, this will occur no matter where the car is. They will need to recoup the cost of transmitting these messages. Due to these business factors, probe-based assessment of pavement quality does not lend itself to a state-by-state deployment. Therefore, there is a role for FHWA and state DOTs to develop a feasible business case, based on collective action.

One model is for state DOTs to contract with traffic data providers to add pavement quality information. This requirement would need to come from a sufficient number of states to make the data collection cost effective. On a per-mile basis the traffic data provider would likely charge much more for pavement quality data than for traffic data, as they have many customers for traffic data (public and private sector) but this would not be the case with pavement quality data (public sector only). The DOT customers would have to cover the full cost of collecting, transmitting, and processing this data. (In an alternative scenario, pavement quality data relating to potholes could have commercial value to carmakers and wireless device application providers in advising drivers of potholes ahead; this would create a larger market for pavement quality data and help to lower the cost to DOTs.) A first estimate of the costs for creating and processing the probe data are found in the next section.

3. Deployment Risks

The following risks are identified:

- market penetration of vehicles equipped to provide probe data may not occur at a high enough rate to create sufficient data for pavement management
- the business case may falter unless states, cities, and the federal government work together to create a stable market of sufficient size to attract investment by data providers and car manufacturers

4. Deployment Constraints

The following constraints are identified:

- the rate at which equipped vehicles will enter the vehicle fleet will be constrained by market conditions
- the quality of pavement data will depend on the performance of the sensors chosen by the car manufacturers for their vehicles

5. Deployment Opportunities

The key to deployment of PDPM is to have enough vehicles reporting pavement-relevant data to be able to contribute to DOT pavement management programs. Some forms of probe data require a particular critical mass of reporting vehicles to keep up with changing conditions on the road; this is the case with traffic monitoring. By contrast, pavement quality changes much more slowly. While traffic can change substantially in a matter of minutes, potholes change on the order of hours (in severe situations) and pavement roughness changes on the order of months or years, depending on usage.

Therefore, even very low levels of PDPM vehicles can have some benefit. The benefit scales up with the number of reporting vehicles until saturation occurs. The total car fleet in the U.S. is about 250M vehicles. If 10% of car fleet is needed to report for accurate traffic information (per the BMW work cited above), it is reasonable to assume 1% is sufficient for relatively slow-changing pavement conditions, or 2.5M vehicles. When might 2.5M vehicles be on the road reporting PDPM data? Approximately 12M vehicles are sold each year in the U.S. Assuming initial introduction and ramp-up of general probe data systems in 2012-2013, the projection is shown in Table 2:

Year	% equipped	# vehicles	Cumulative sum
2014	.5	60,000	60,000
2015	1	120,000	180,000
2016	1	120,000	300,000
2017	2	240,000	540,000
2018	2	240,000	780,000
2019	4	480,000	1,260,000
2020	5	600,000	1,860,000
2021	5	600,000	2,460,000

Table 2 – Estimated projection of PDPM vehicles

Therefore, the earliest timeframe for a “full” deployment of PDPM would be early in the next decade. Nevertheless, beneficial data would begin flowing much sooner.

For instance, a sophisticated telematics system such as GM’s OnStar has access to the vehicle database as well as a cellular communications link. On purely a technical level, they could start collecting PDPM data now from millions of vehicles already on the road. Whether OnStar would find this an interesting proposition in terms of their stated business focus of Safety and Security is another question. However the automotive telematics industry is moving at a very fast pace currently and many other players are candidates for initial delivery of pavement-relevant probe data. In the course of discussions to prepare this report, one car company spoke of their interest in conducting pilots in the near term to understand the value of their data to DOTs.

Car companies are able to sell probe-based traffic data to data providers and could do the same with pavement-relevant data if a market exists.

What about aftermarket systems? The USDOT cooperative system program relies heavily on aftermarket devices and “Here I Am” devices to create a greater density of communications interaction, to support mainly safety applications. While this approach is useful for safety, the PDPM application requires reliable kinematics data from accelerometers and rate gyros. These must be mounted on the vehicle in such a way that the road surface components are transmitted to the sensor. Aftermarket/HIA devices, as defined by the USDOT program, do not lend themselves to this type of installation and therefore it is doubtful they would contribute to creating PDPM data. However, new requirements could be defined such that HIA devices incorporate the accelerometers and rate gyros needed for PDPM.

Fuel Economy and Pavement Quality

Within a DOT, the fuel economy aspects of rolling resistance can be important in justifying maintenance budgets in terms of the overall economic costs of under-maintained pavement and serve as further justification for investments in PDPM. As seen in Figure 1 fuel economy data from past fleet operations on the NCAT Pavement Test Track have suggested a relationship between fuel economy and changing pavement roughness. In order to account for the potentially confounding effect of vehicle wear and tear, a research program was undertaken to measure rolling resistance on the surface of all experimental pavements on the same truck within a single day of fleet operations. As seen in Figure 2, distinct differences in rolling resistance were observed within each section. It is expected that future research will identify a relationship between various pavement surface characteristics such as roughness, macro-texture, friction, etc. Data collected for such a research program could be used to consider the effect of these same surface conditions on changing fuel economy in passenger vehicles.

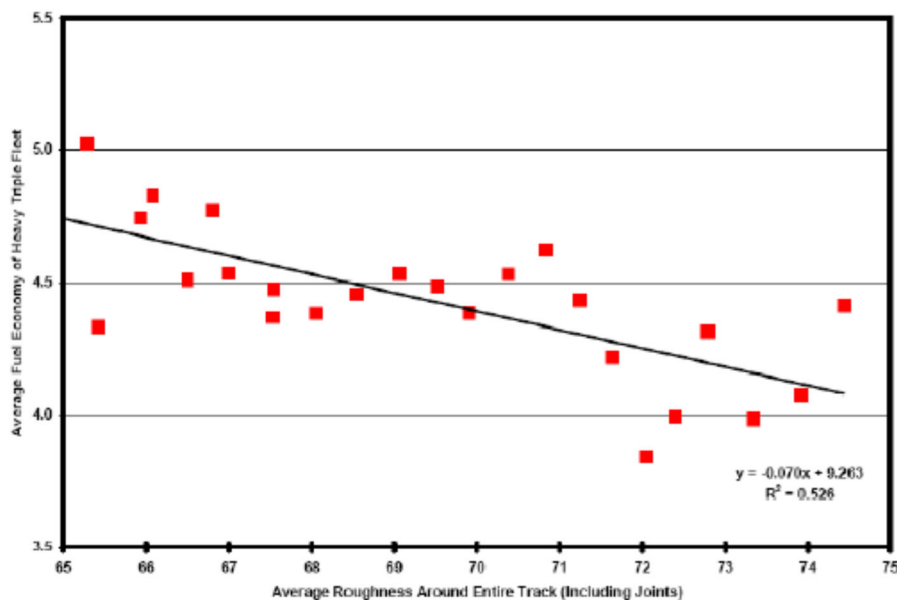

Figure 18 – Average Fuel Economy of Truck Fleet as the average road roughness increases

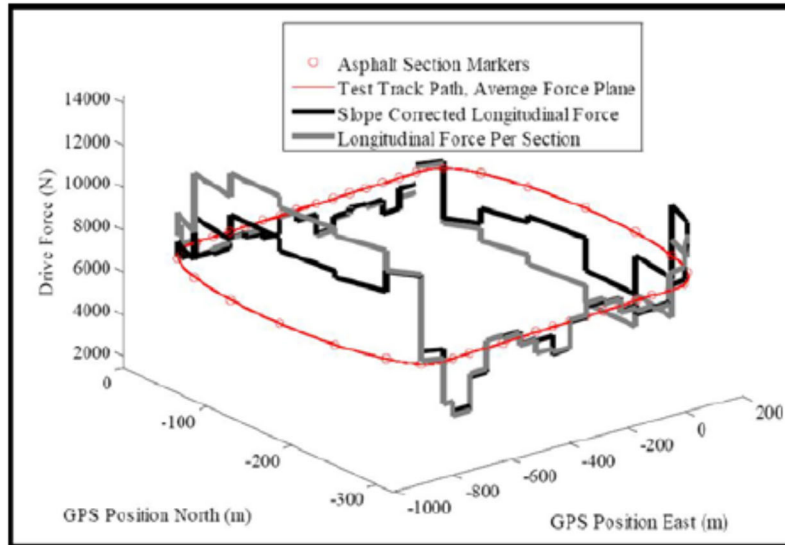

Figure 19 – Plot showing drive force for various track section with varying roughness

VIII. Cost analysis

Pavement assessment is an essential part of road management for transportation agencies. Knowing the condition of pavement enables agencies to allocate resources to road repairs and maintain their targeted levels of road quality. The core question for PDPM is how it compares in cost terms to current methods used by the states. An approximate comparison is provided in this section.

1. Vehicle/Data Costs

A reliable automotive source with experience in probe data estimates that the additional air-time cost per car for sending pavement-relevant data is \$5 per vehicle per year. This is for only transmitting event-based data, with reporting thresholds the DOTs could adjust. The number of vehicles reporting within a geographic area, or within a timeframe, can be managed, so the DOT could tradeoff cost against penetration rate. For instance, geo-bounds could be applied so that data only for a specific road segment is reported, and data could be collected daily, weekly, or monthly, etc. to control costs.

As noted above, a PDPM fleet of 2.5M vehicles is estimated to be sufficient. At \$5 per vehicle per year, the annual cost for transmission of data would be \$12.5M. For estimation purposes, assume the probe data processor would add another \$5 per vehicle per year for their services. The total costs in this scenario would be \$25M annually for national coverage.

Pricing from a service provider would have to recoup initial costs from a relatively small pool of states. Assuming 10 states form the initial market the cost per state is \$2.5M.

2. Current Pavement Assessment Costs

The cost reported by state DOTs for the in-house delivery of network level IRI data is between \$10 and \$20 per lane mile, averaging approximately \$15 per lane mile. In comparison, the cost reported by state DOTs for the delivery of network level IRI data collected by consultants working as out-source contractors is between \$20 and \$30 per lane mile, averaging \$25 per lane mile. The out-source costs for delivered data are higher because of the additional burden of contract management, quality assurance for delivered data, etc.

Using these average figures, costs for some representative states, plus a national cost, are estimated and shown in Table 3:

Location	Lane Miles	Cost at In-House Rate (\$15/mile)	Cost at Contracted Rate (\$25/mile)
Alabama	200,000	\$3.00M	\$ 5.00M
California	390,000	\$5.85M	\$ 9.75M
Michigan	250,000	\$3.75M	\$ 6.25M
Texas	650,000	\$9.75M	\$16.25M
Virginia	160,000	\$2.40M	\$ 4.00M
USA	8,500,000	\$127.5M	\$212.5M

Table 3 – Current Per-Lane-Mile Costs for IRI measurements

3. Cost Comparison

The \$25M figure calculated above for PDPM is between 12-20% of the national cost depending on the approach used (in-house versus contracted). In an early deployment scenario in which only ten states were bearing the \$25M cost burden, the cost advantage for PDPM would depend on the lane mileage within the state. In the table above, PDPM costs of \$2.5M per state would be lower for all the states shown except for Virginia, compared to current methods.

4. Discussion

The current collection method of acquiring network level IRI data conducted by the states is a reliable process. Data will be delivered for the roads and lane-miles targeted by the state with their own resources. PDPM, because it relies on independent actors, is a different sort of animal. It can provide extensive coverage on a daily basis yet the specific roads and the amount of data collected is uncertain. While IRI data collected by states could be phased out in the far future when PDPM-reporting vehicles are ubiquitous, there will inevitably be a transition period as the market matures and increasing numbers of vehicles are equipped.

IX. Conclusions and Recommendations

PDPM offers the potential for cost-effective pavement assessment using sensors already on today's automobiles. The roll-out of probe data services in the U.S. by car-makers is expected to begin near-term, based on existing approaches overseas. However, PDPM does not offer the type of business case to car-makers that traffic and weather information do. Therefore, the

infrastructure community needs to stimulate a PDPM pavement data market at the national level, to motivate data providers to seek this information, which will motivate car companies to provide it.

The research team recommends that a pilot program be conducted with one or more states plus a car company who is a leader in probe data and has mature on-board systems that can easily provide probe data via cellular communications. The objective of the pilot study would be to take the results of Auburn's study to a real-world setting, to gain experience with both the quality of the data as well as reporting management techniques. The pilot could also engage data service providers to begin to conceptualize a delivery mechanism to state DOTs.

It should be noted that the implementation of PDPM may require a shift in philosophy regarding allocation of resources traditionally used for IRI measurements. The shift could be in defining "how much is good enough" when using non-deterministic data sources. Looking towards the long term, it is likely that state-operated IRI pavement evaluation will continue for some time, with PDPM data assisting in increasing degrees over the years to help deploy road maintenance resources more efficiently.